

### High Cycle Actuation CSA CERTIFIED



*Available in Manual Override*

#### Reversing Motors

Elite Valve Canada electric motors have been design specifically for valve and damper automation. Motors selected must be instantly reversible with equal torque in both CW and CCW directions. All motors must meet our inflexible specifications before being design into our electric actuators.

#### Easy Adjustment

Color-coded cam-adjusted limit switches assure fast and easy field fine-tuning of the actuator end positions.

#### Permanent Lubrication

The lubricant selected for Elite Valve Canada's actuators is suitable for countless applications through a wide range of temperatures. Elite Valve actuators are permanently lubricated requiring little or no maintenance over years of service.

#### Features

Designed for High Performance Long Life

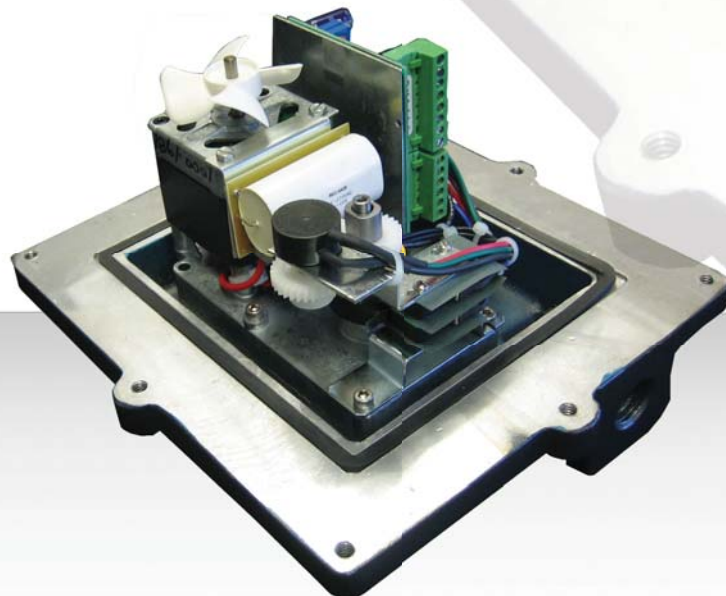

## SPECIFICATIONS:

<b>Torque</b>	400 Lb-In model EA00400 675 Lb-In model EA00675 1000 Lb-In model EA01000 1500 Lb-In model EA01500	<b>L. R. Current</b>	115Vac EA00400 & EA00675 = 0.75 115Vac EA01000 & EA01500 = 0.99 230Vac EA00400, EA00675, EA01000 & EDO1500=0.38 amps 12Vdc 4.2 amps, 24Vdc 2.6 amps
<b>Cycle time</b>	EA00400 10 seconds/90° 115, 230Vac & 12Vdc EA00400 20 seconds/90° 75% duty, 24Vdc & 24Vac EA00675 & EA01000 15 seconds/90° 115, 230Vac & 12Vdc EA00675 & EA01000 30 seconds/90° 75% duty, 24Vdc & 24Vac EA01500 30 seconds/90° 115, 230Vac & 12Vdc EA01500 70 seconds/90° 75% duty, 24Vdc & 24Vac	<b>Motor</b>	Permanent split capacitor 115Vac/1ph/50-60Hz standard With thermal over load protection 25% standard 115Vac & 230Vac 75% optional 75% 12Vdc, 24Vdc & 24Vac
		<b>Duty Cycle</b>	

<b>Enclosure Coating</b>	NEMA 4 standard Thermally bonded polyester powder
<b>Fasteners</b>	300 series stainless steel
<b>Output</b>	ISO 5211 F07 300 series stainless steel
<b>Mounting Pad</b>	ISO 5211 F07
<b>Over Ride</b>	Manual, declutching
<b>Brake</b>	Friction, standard
<b>Position Ind.</b>	Visual indicator Wired for light indication
<b>Weight</b>	13 Lbs.
<b>Lubrication</b>	Permanent
<b>Installation</b>	Universal
<b>Temp. Range</b>	-40° F. to 150° F. Heater & thermostat required 0° F. & below
<b>Switches</b>	SPDT snap action 16 amp ½ HP 125, 250Vac, 0.5amp 125Vdc

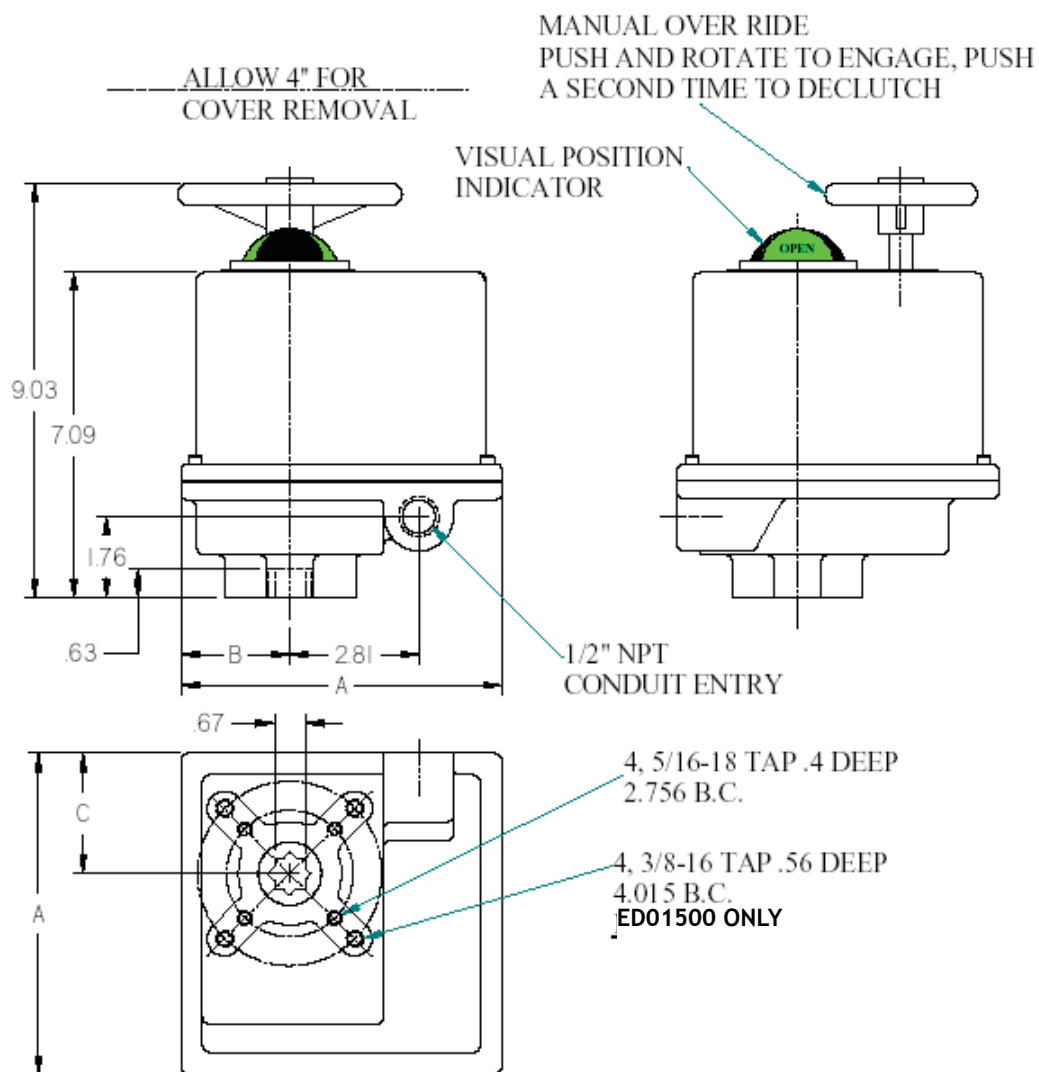

MODEL	DIMENSIONS		
	A	B	C
EA00400, EA00675, EA01000	7.0	2.38	2.63
EA01500	8.5	3.13	3.38

Elite Valve Canada  
775 Roper Street  
Sarnia, Ontario, Canada  
N7S 5G7  
www.elitevalve.com